

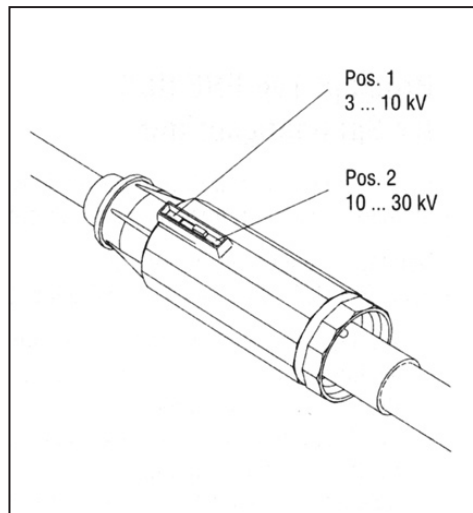

Detectors for HV Systems

Voltage Detector Type PHEIII - Switchable



Features:

Insulating operating rod	Foam-filled fibreglass 30mm dia, tested to IEC 60855, detachable for easy storage
Indicator unit	Fully insulated grey plastic
Indication	Visual LEDs and acoustic signal
Test probe	Fibreglass-reinforced epoxy resin Interchangeable for switchgear and overhead lines Detachable for easy storage
Probe electrode	Tinned copper, removable, for switchgear and overhead lines
Discharge current	Less than 0.5mA
Application	Type "S" for switchgear and overhead lines Suitable for use in wet weather

Indications:

Self-test	Push button - single acoustic signal, then steady green light
Ready for operation	Steady green light
Voltage present	Flashing red light and acoustic signal

Operating instructions available on request from Thew & McCann