



OH Line Stringing Roller

Universal Stringing Roller



Description:

- ① A versatile stringing roller with cast aluminium frame, a choice of sheaves - either smooth face aluminium or nylon, mounted on precision bearings. Supplied with galvanised socket head fitting for direct attachment to suspension ball fitting. The hinged side gate latch is designed for hand or hot stick operation. Working load is 10kN.
- ② An optional cast aluminium crossarm adaptor is available for crossarm mounting the stringing roller. Adaptor suits crossarms 75-180mm width + 70 - 180mm height.

Weight: ① 5kg (aluminium sheave), 4.5kg (nylon sheave)

② 1.6kg

Code: ① USRA (aluminium sheave)

USRN (nylon sheave)

② USB-1 (crossarm adaptor)



OH Line Stringing Roller

Universal Stringing Roller

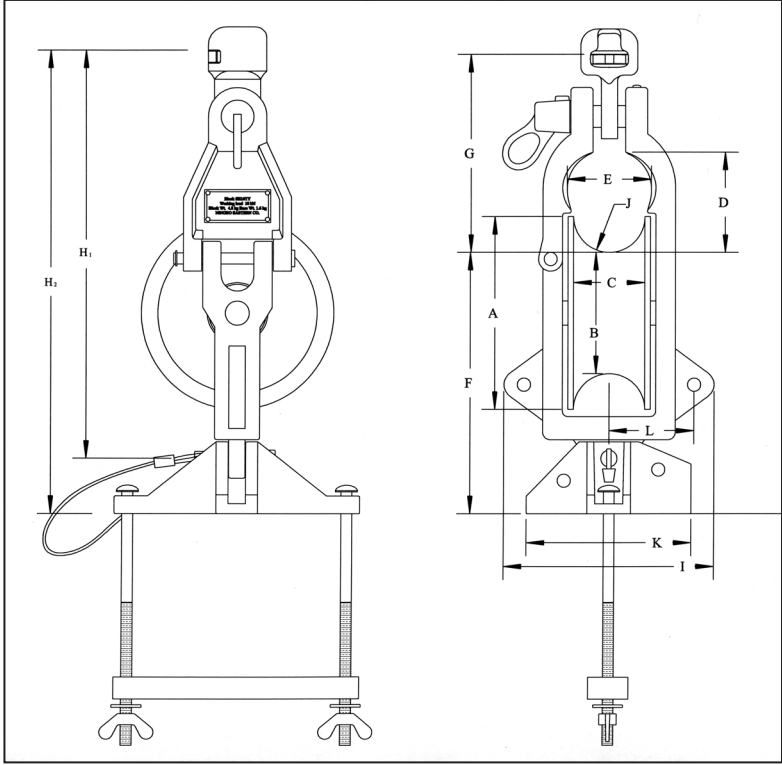

CODE	SHEAVE mm			THROAT mm		Height above Crossarm		Overall Length		Width of Widest Point	Radius	Width of Crossarm Bracket	Centre of Sheave to mounting hole
	OD	ID	Width	OD	ID	mm		mm		mm	mm	mm	mm
	A	B	C	D	E	F	G	H1	H2	I	J	K	L
USRA & USRN	180	112	64	90	78	2.45	175	365	420	190	25	150	75

